

# GLAZED FIBERGLASS PATIO DOOR SINGLE w/ or w/out SIDELITE(S) OUTSWING "IMPACT"

**GENERAL NOTES**

1. This product evaluation drawing has been developed in compliance with the 7th Edition (2020) Florida Building Code (FBC) including the "High Velocity Hurricane Zone" (HVHZ).
2. Product anchors shall be as listed and spaced as shown on details. Anchor embedment to base material shall be beyond wall dressing or stucco.
3. When used in the "HVHZ", this product complies with Section 1626 of the FBC and does not require an impact resistant covering.
4. When used in areas outside of the "HVHZ" requiring wind borne debris protection, this product complies with FBC Sections 1609.1.2 & R301.2.1.2 and does not require an impact resistant covering. This product meets missile level "D" and includes Wind Zone 4 as defined in ASTM E 1996 and FBC Sections 1609.1.2.2 & R301.2.1.2.1.
5. For 2x stud framing construction, anchoring of these units shall be the same as that shown for 2x buck masonry construction.
6. Site conditions that deviate from the details of this drawing require further engineering analysis by a licensed engineer or registered architect.
7. This product meets the water infiltration requirements for the "HVHZ".

TABLE OF CONTENTS		
SHEET #	DESCRIPTION	SHEET #
1	Typical Elevations, Design Pressures & General Notes	7
2	Door & Sidelite Panel Details	8
3	Lite Frame Glazing Details	9
4	Elevations	10
5	Horizontal & Vertical Cross Sections	11
6	Horizontal & Vertical Cross Sections (2X Buck)	12

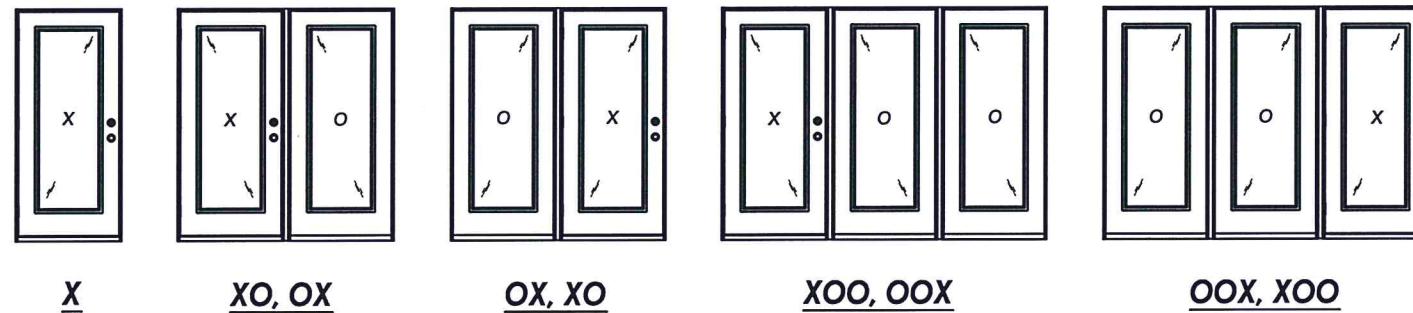
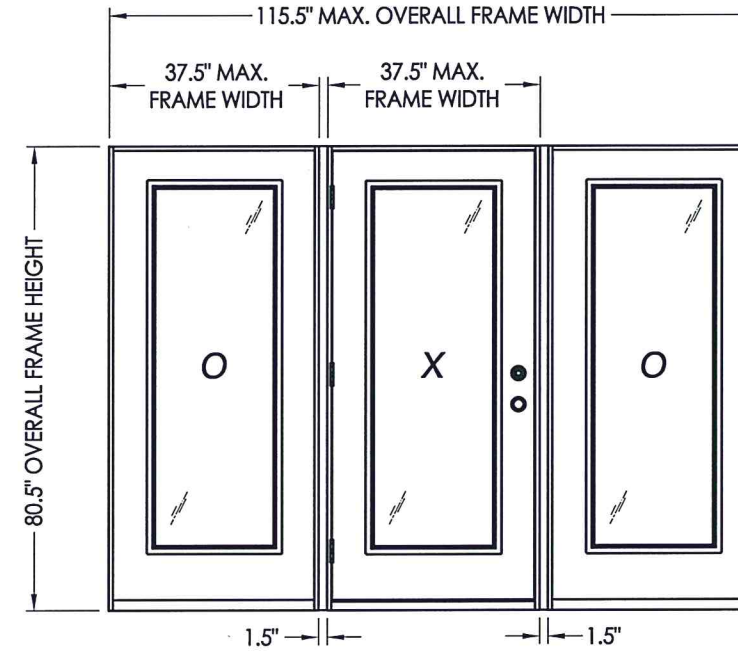

CONFIGURATION	MAX. FRAME DIMENSION	JAMB REINFORCEMENT	DESIGN PRESSURE (PSF) INSWING		DESIGN PRESSURE (PSF) OUTSWING	
			POSITIVE	NEGATIVE	POSITIVE	NEGATIVE
X	37.5" x 80.5"	N/A	+50.0	-50.0	+50.0	-50.0
OX, XO	76.5" x 80.5"	2X	+50.0	-50.0	+50.0	-50.0
OXO, XOO, OOX	115.5" x 80.5"	2X	+50.0	-50.0	+50.0	-50.0

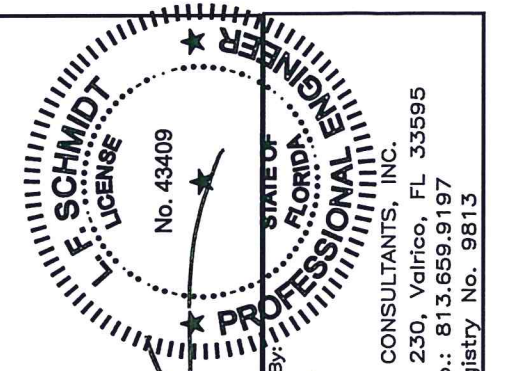

February 8, 2021  
 Documents Prepared By:  
 Lyndon F. Schmidt  
 P.E. No. 43409  
 R.W. BUILDING CONSULTANTS, INC.  
 P.O. Box 230, Valrico, FL 33595  
 Phone No.: 813.659.9197  
 FBPE Registry No. 9813

PRODUCT: TRINITY FIBERGLASS PATIO DOOR "Impact"  
 PART OR ASSEMBLY: TYPICAL ELEVATION, DESIGN PRESSURES & GENERAL NOTES

NO.	DATE	BY	REVISIONS

DATE: 1/28/21  
 SCALE: N.T.S.  
 DWG. BY: RW  
 CHK. BY: LFS  
 DRAWING NO.: FL-37184.1  
 SHEET 1 of 12

Z:\Clients\Trinity Glass PERMANENTVA - Florida Product Approvals\FL - 37184\C - Drawings\FL-37184 (2020)\FL-37184.1.dwg

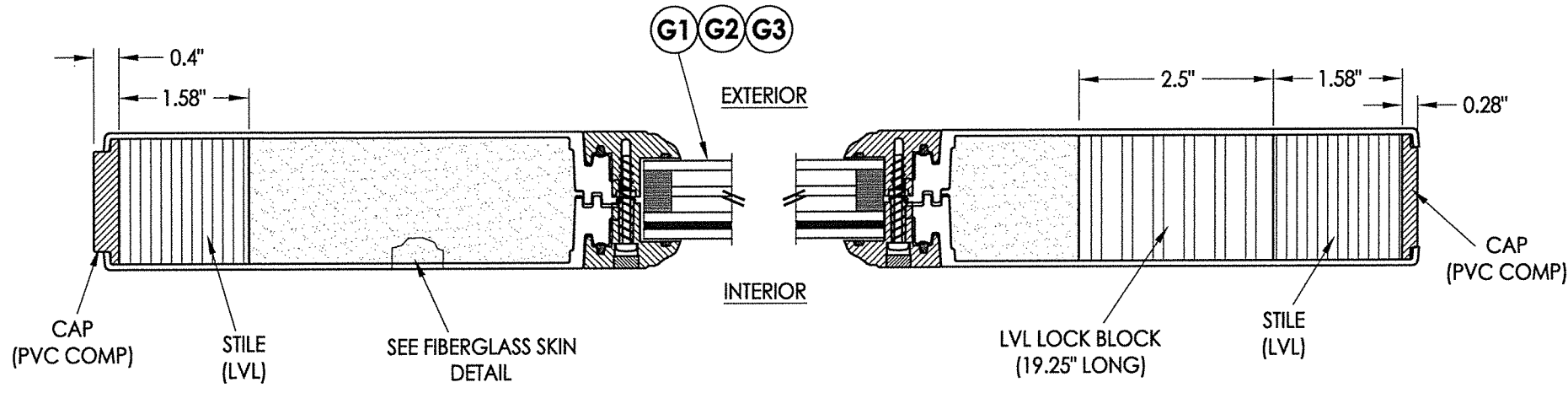

**1** HORIZONTAL CROSS SECTION  
**2**

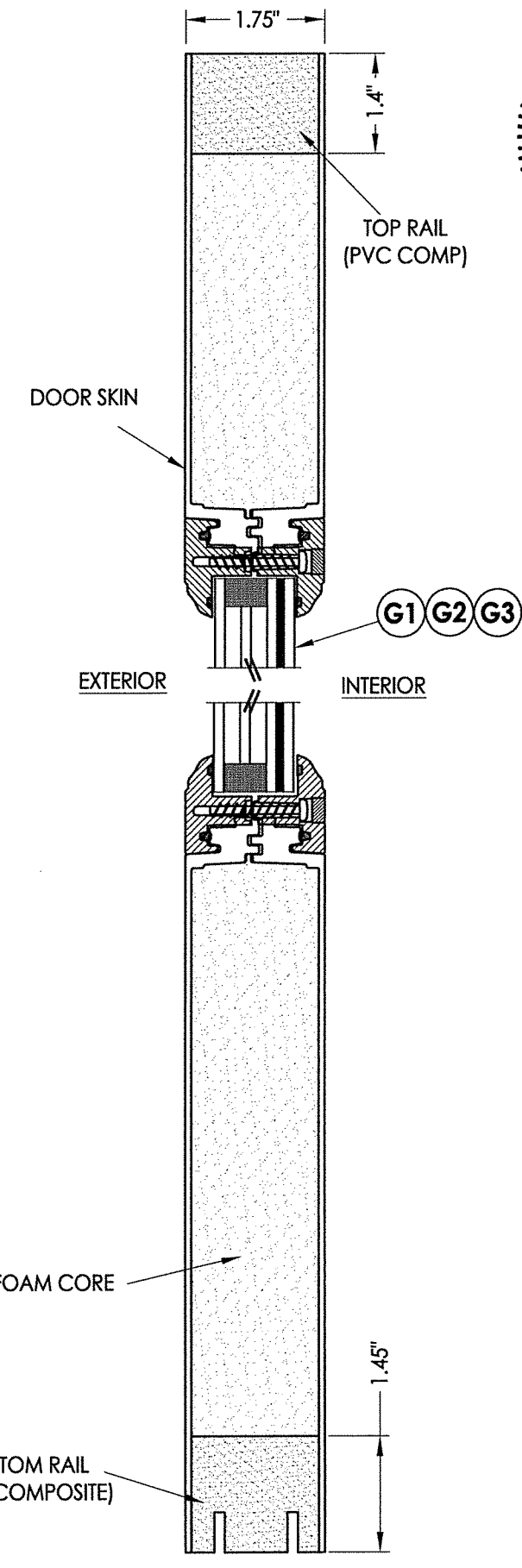
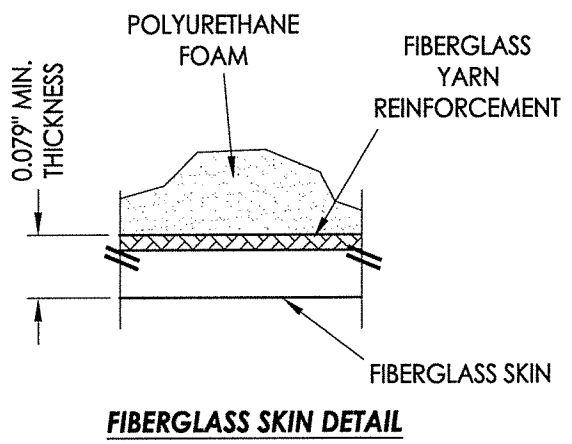
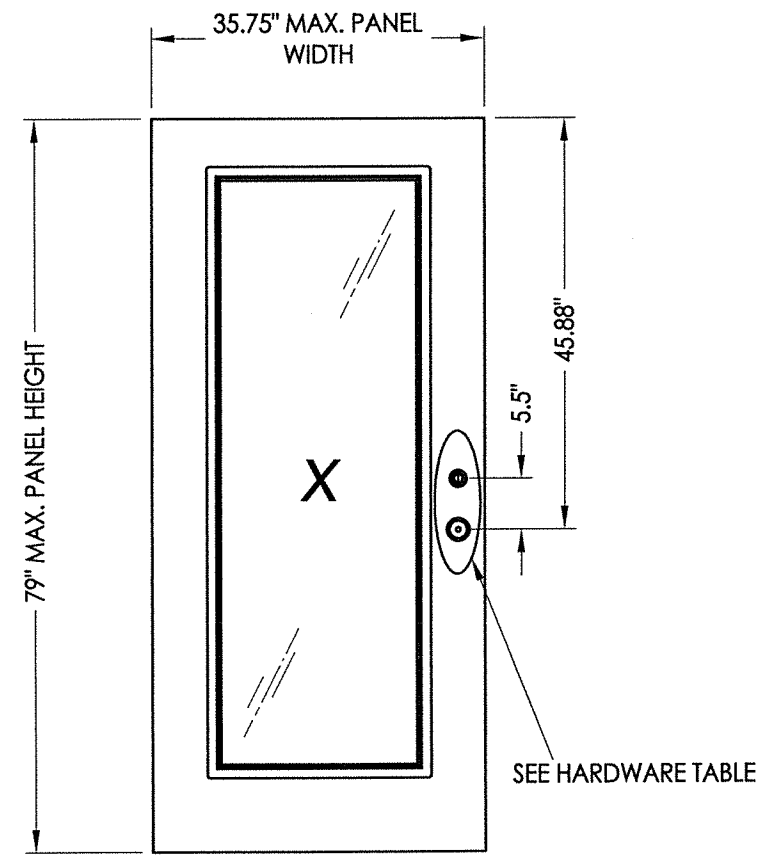

**2** VERTICAL CROSS SECTION  
**2**

- 40** FIBERGLASS DOOR PANEL
- 50** FIBERGLASS SIDELITE PANEL

HARDWARE TABLE	
MANUFACTURER	MODEL
SCHLAGE	KNOB: F51 DEADBOLT: B60N

FIBERGLASS SKIN: 0.079" MIN. THK. (F<sub>y</sub> = 10,000 PSI MIN.)  
FOAM CORE: POLYURETHANE - 1.9 PCF MIN.)

February 8, 2021  
 Documents Prepared By: Lyndon F. Schmidt  
 P.E. No. 43409  
 R.W. BUILDING CONSULTANTS, INC.  
 P.O. Box 230, Valrico, FL 33595  
 Phone No.: 813.659.9197  
 FBPE Registry No. 9813

PRODUCT:	TRINITY FIBERGLASS PATIO DOOR "Impact"
PART OR ASSEMBLY:	DOOR & SIDELITE PANEL DETAILS
DATE:	1/28/21
SCALE:	N.T.S.
DWG. BY:	RW
CHK. BY:	LFS
DRAWING NO.:	FL-37184.1
SHEET	2 OF 12

© 2021 R.W. BUILDING CONSULTANTS INC.





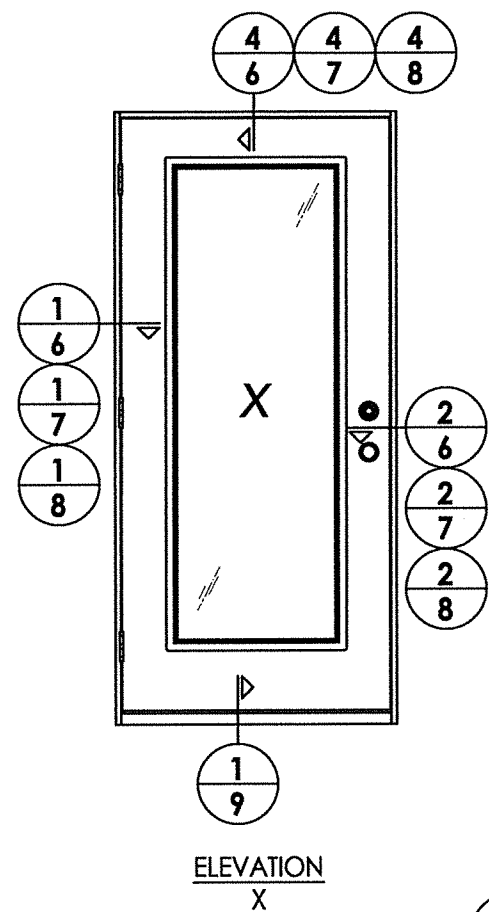

ELEVATION  
X

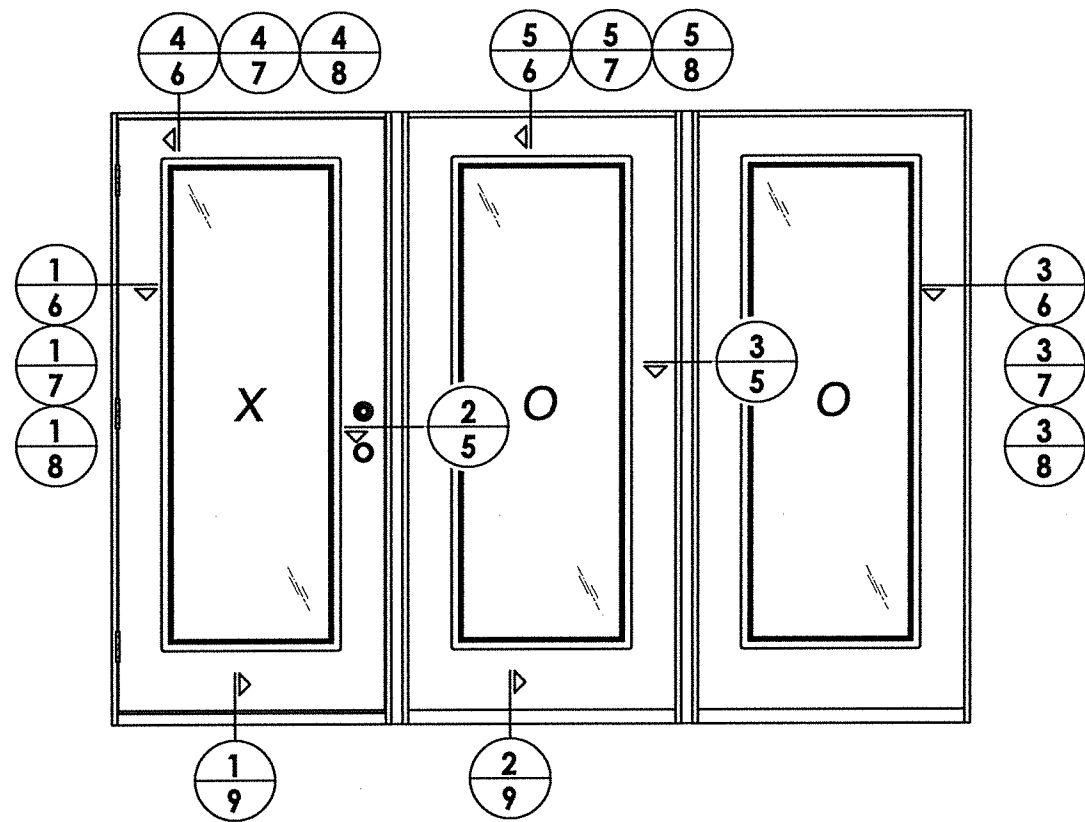

ELEVATION  
XOO / OOX (SHOWN)  
XO / OX (SIMILAR)

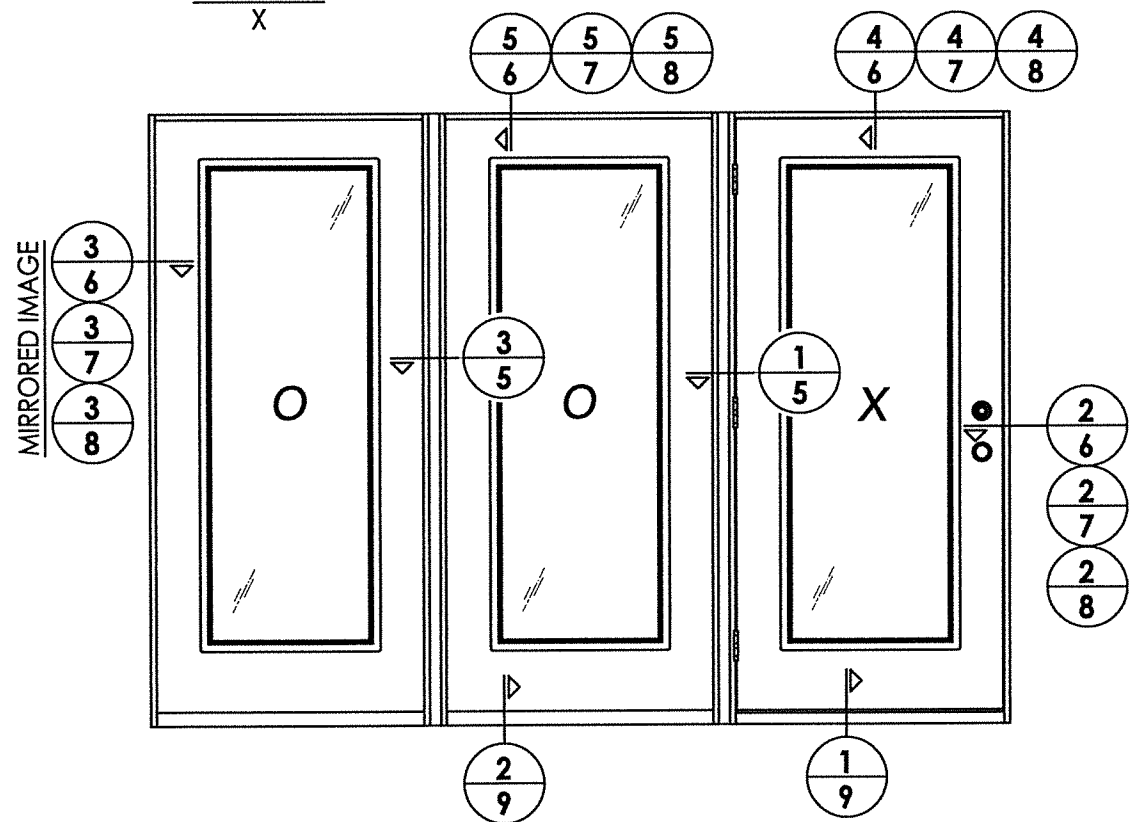

ELEVATION  
OOX / XOO (SHOWN)  
OX / XO (SIMILAR)  
(CENTER HINGED)

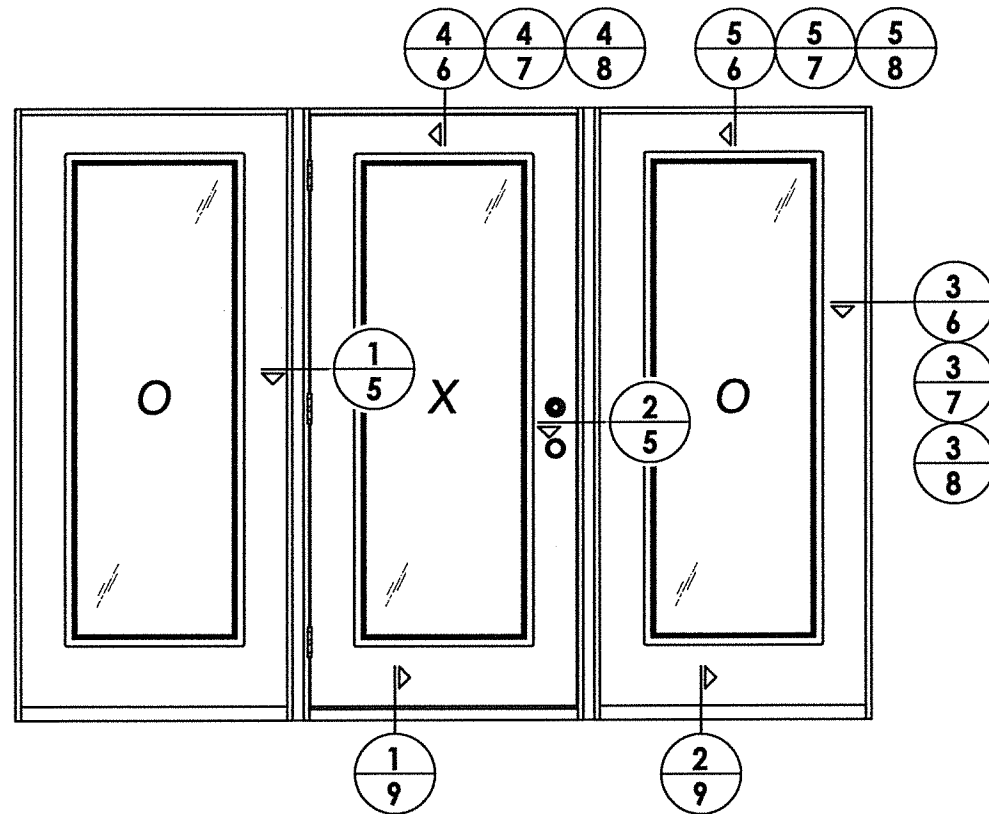

ELEVATION  
OXO

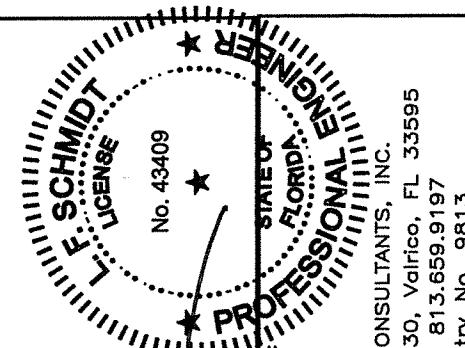

*LFS*

February 8, 2021

Documents Prepared By:  
Lyndon F. Schmidt  
P.E. No. 43409

*RW*  
BUILDING CONSULTANTS, INC.  
P.O. Box 230, Vairico, FL 33595  
Phone No.: 813.659.9197  
FBPE Registry No. 9813

PRODUCT: TRINITY  
FIBERGLASS PATIO DOOR  
"Impact"  
PART OR ASSEMBLY:  
ELEVATIONS

NO.	DATE	BY	REVISIONS

DATE: 1/28/21

SCALE: N.T.S.

DWG. BY: RW

CHK. BY: LFS

DRAWING NO.:  
FL-37184.1

SHEET 4 OF 12

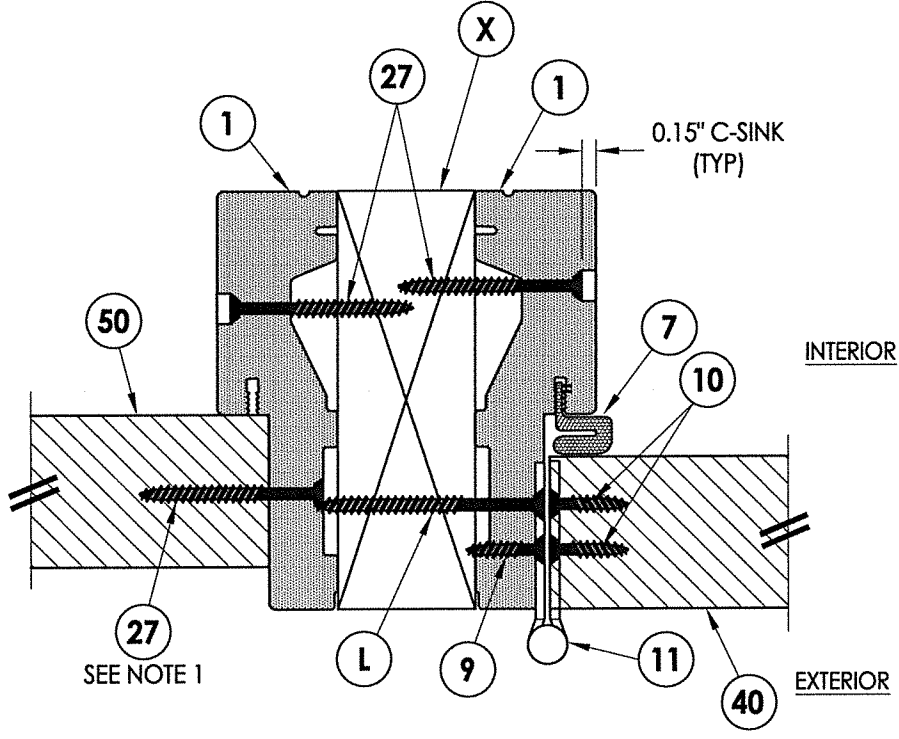

**1**  
**5** HORIZONTAL CROSS SECTION

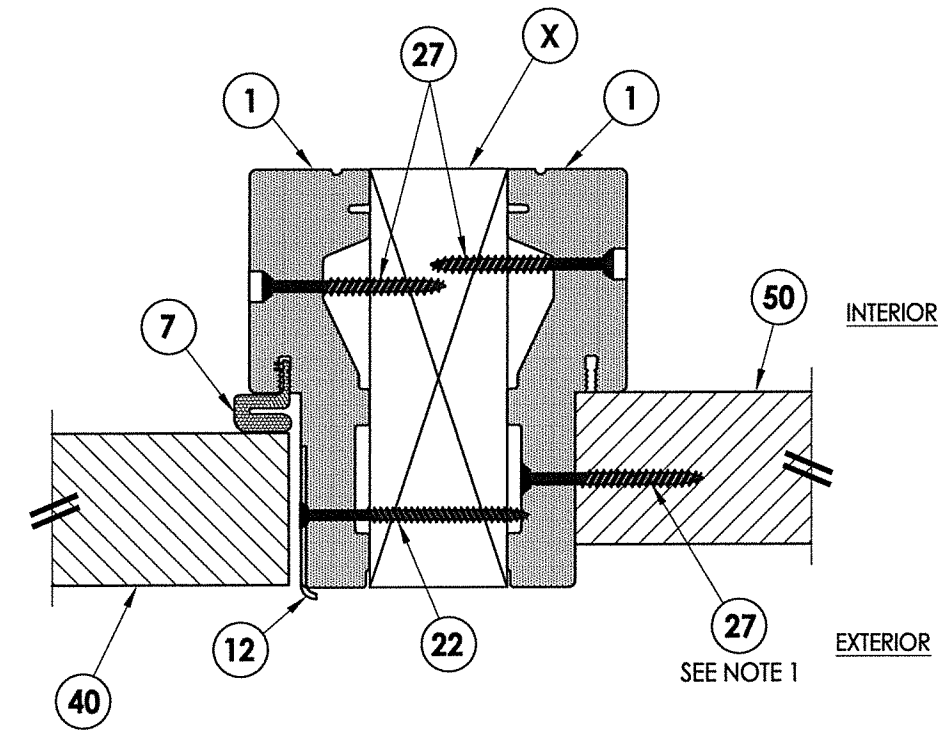

**2**  
**5** HORIZONTAL CROSS SECTION

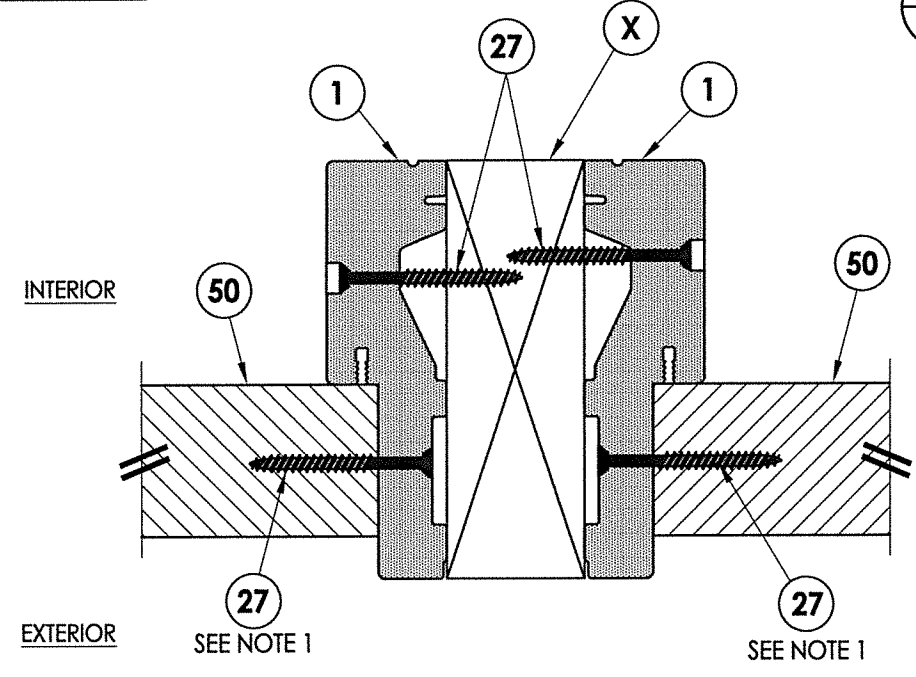

**3**  
**5** HORIZONTAL CROSS SECTION

Notes:  
1. Sidelite assembly screws located 6" from each end and 4 more screws equally spaced between (6 screws total per side jamb).

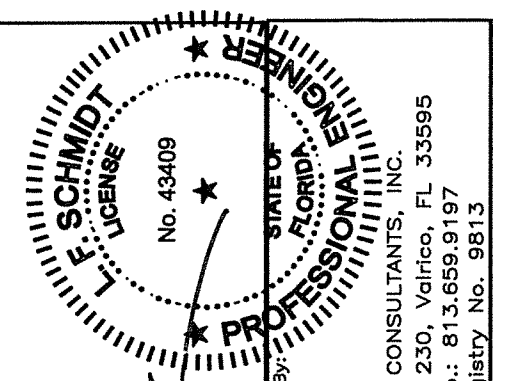

February 8, 2021  
 Documents Prepared By:  
 Lyndon F. Schmidt  
 P.E. No. 43409  
 R.W. BUILDING CONSULTANTS, INC.  
 P.O. Box 230, Valrico, FL 33595  
 Phone No.: 813.659.9197  
 FBPE Registry No. 9813

PRODUCT:	TRINITY FIBERGLASS PATIO DOOR "Impact"
PART OR ASSEMBLY:	HORIZONTAL CROSS SECTIONS
NO.	DATE
BY	REVISIONS
DATE:	1/28/21
SCALE:	N.T.S.
DWG. BY:	RW
CHK. BY:	LFS
DRAWING NO.:	FL-37184.1
SHEET	5 OF 12

Z:\Clients\Trinity Glass PERMANENTVA - Florida Product Approvals\FL - 37184C - Drawings\FL-37184 (2020)\FL-37184.1.dwg

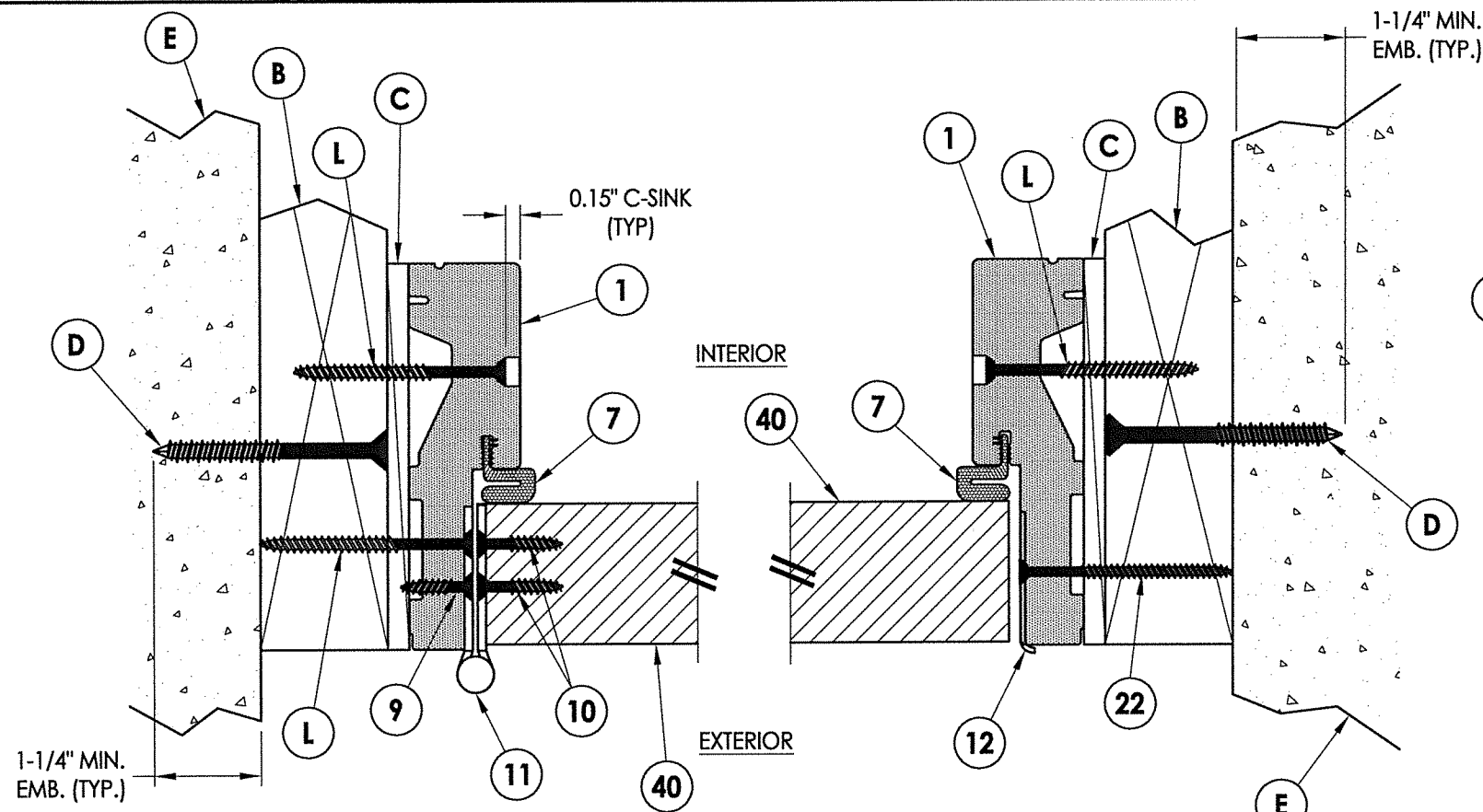

**1**  
**6** HORIZONTAL CROSS SECTION

**2**  
**6** HORIZONTAL CROSS SECTION

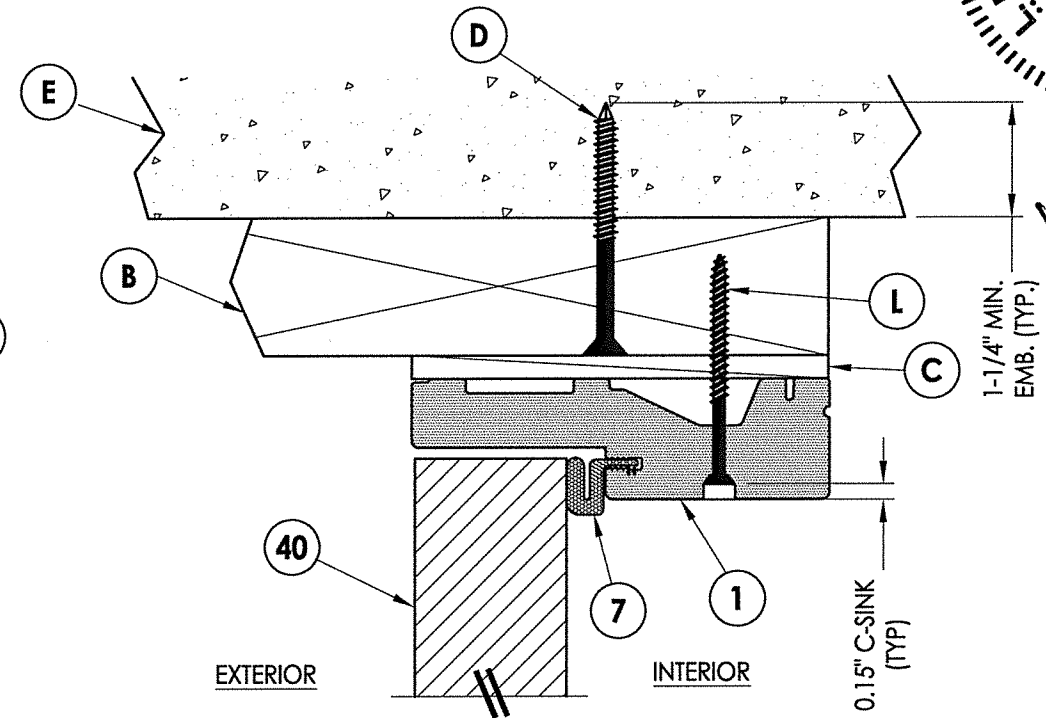

**4**  
**6** VERTICAL CROSS SECTION

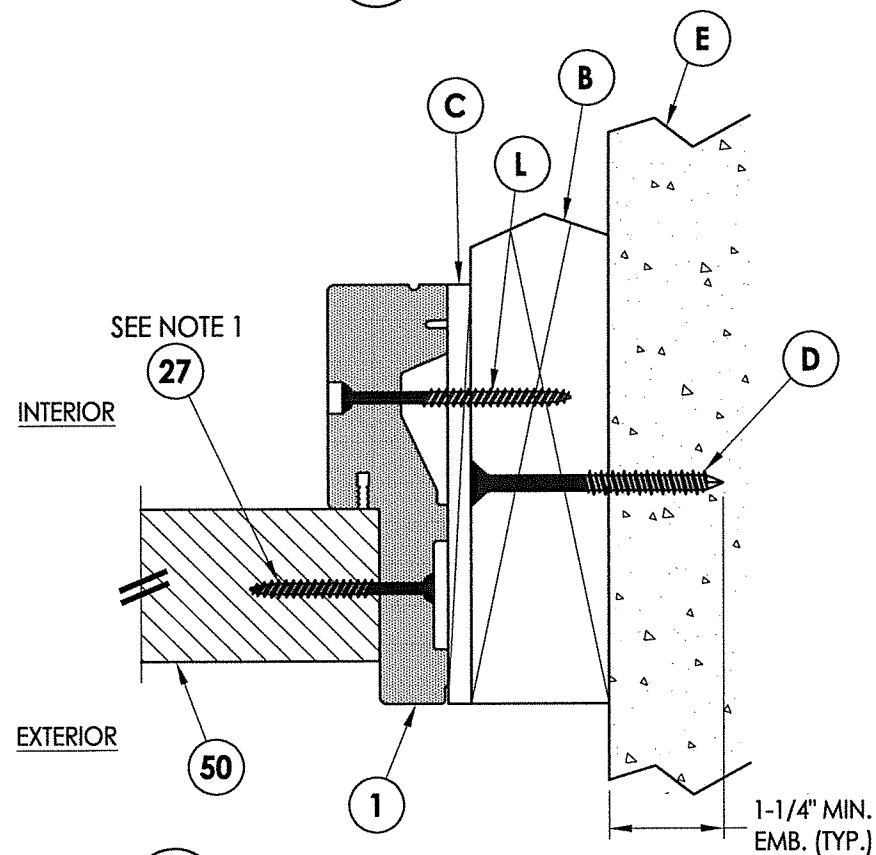

**3**  
**6** HORIZONTAL CROSS SECTION

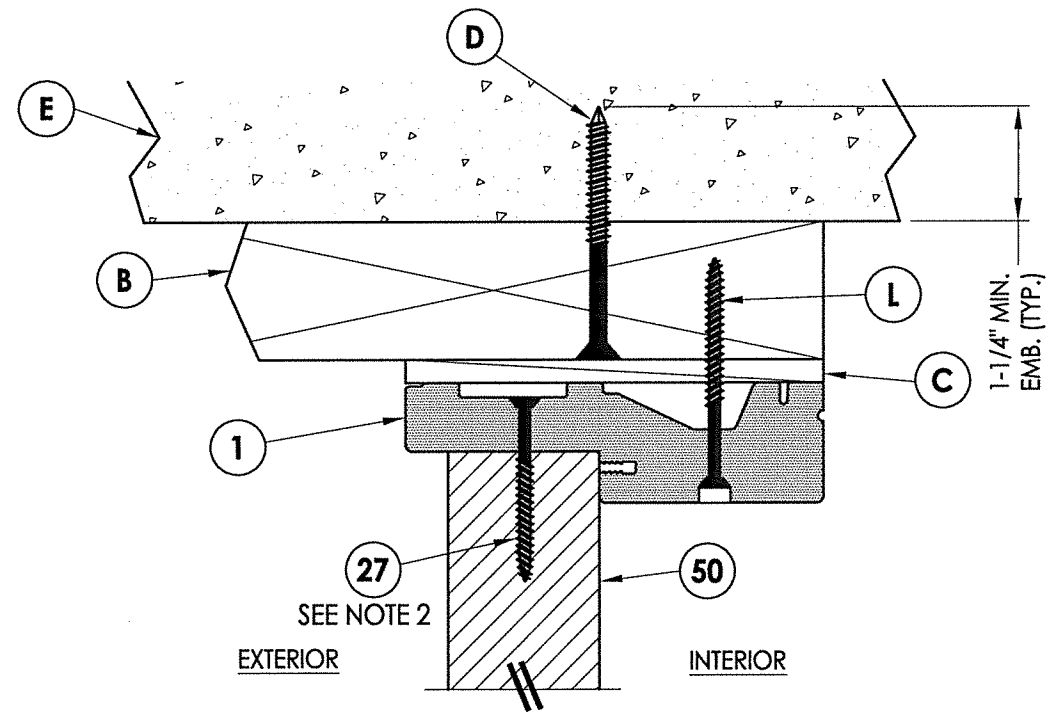

**5**  
**6** VERTICAL CROSS SECTION

**Notes:**

1. Sidelite assembly screws located 6" from each end and 4 more screws equally spaced between (6 screws total per side jamb).
2. Sidelite assembly screws located 10" from each end (2 screws total along head & sill).

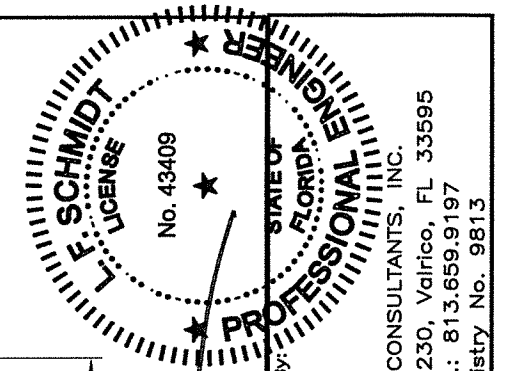

February 8, 2021  
 Documents Prepared By:  
 Lyndon F. Schmidt  
 P.E. No. 43409

R.W.  
 BUILDING CONSULTANTS, INC.  
 P.O. Box 230, Vairico, FL 33595  
 Phone No.: 813.659.9197  
 FBPE Registry No. 9813

PRODUCT:	TRINITY FIBERGLASS PATIO DOOR "Impact"
PART OR ASSEMBLY:	HORIZONTAL & VERTICAL CROSS SECTIONS (2X BUCK)

NO.	DATE	BY	REVISIONS

DATE:	1/28/21
SCALE:	N.T.S.
DWG. BY:	RW
CHK. BY:	LFS
DRAWING NO.:	FL-37184.1
SHEET	6 OF 12

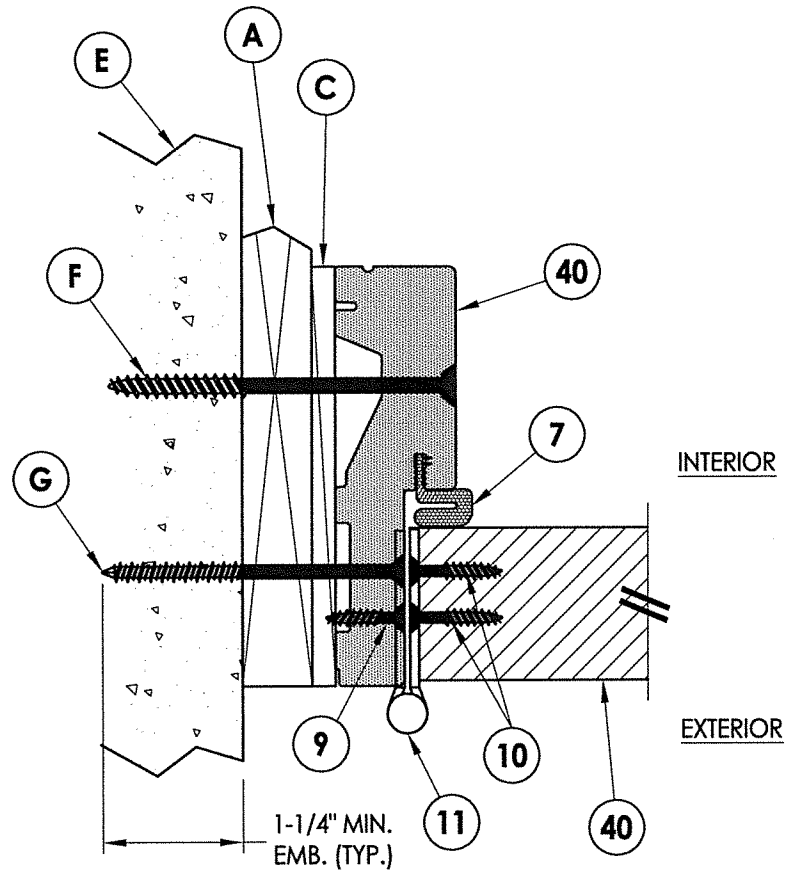

**1 HORIZONTAL CROSS SECTION**  
7 Shown w/ 1X sub-buck

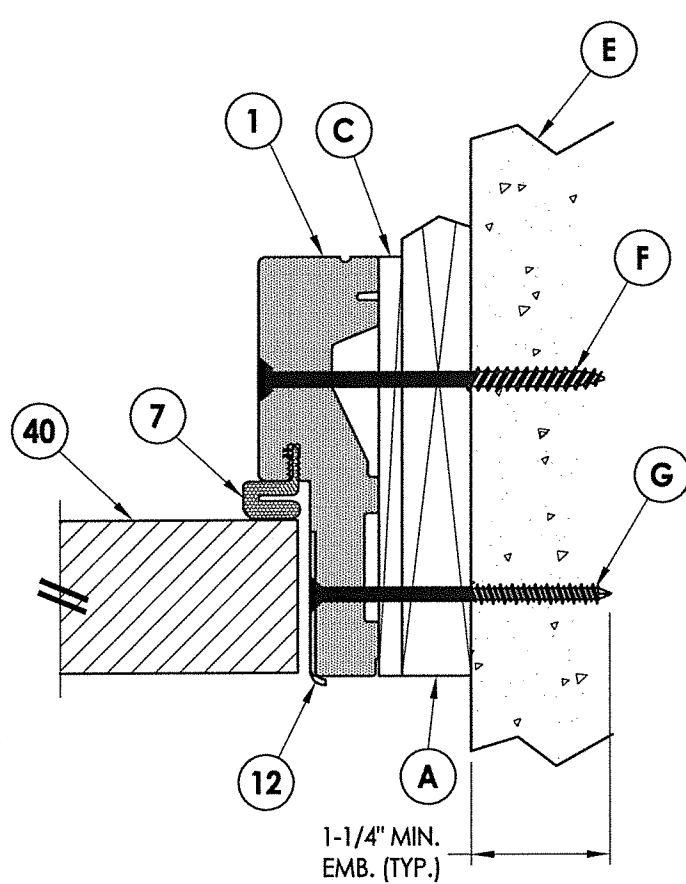

**2 HORIZONTAL CROSS SECTION**  
7 Shown w/ 1X sub-buck

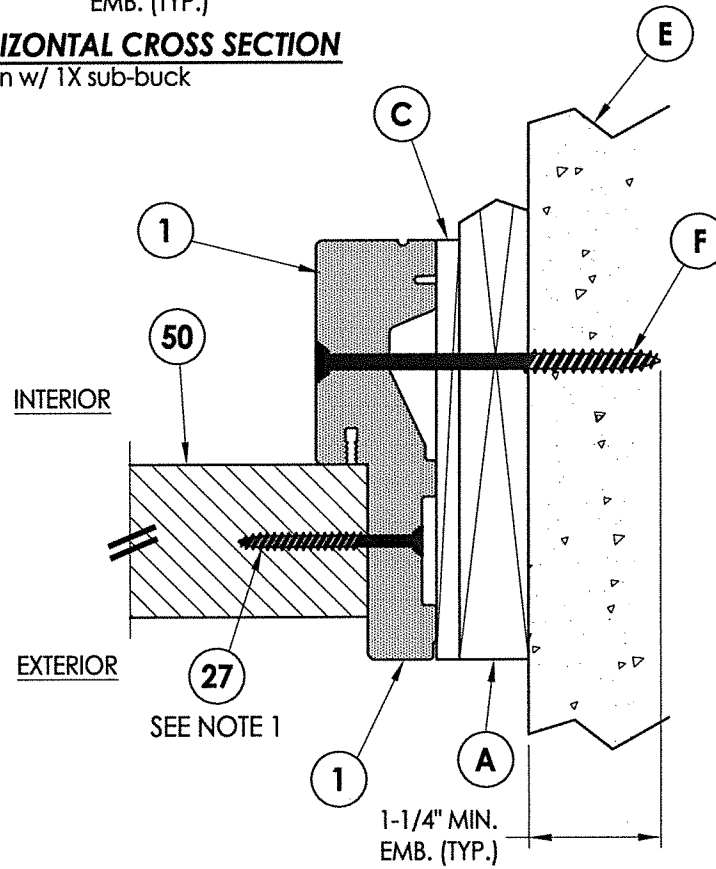

**3 HORIZONTAL CROSS SECTION**  
7 Shown w/ 1X sub-buck

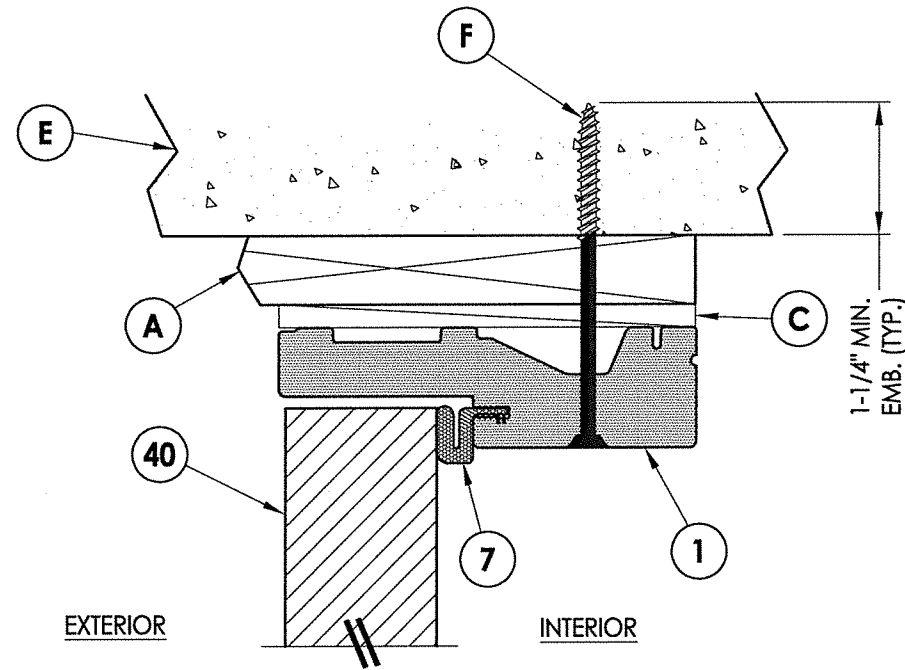

**4 VERTICAL CROSS SECTION**  
7 Shown w/ 1X sub-buck

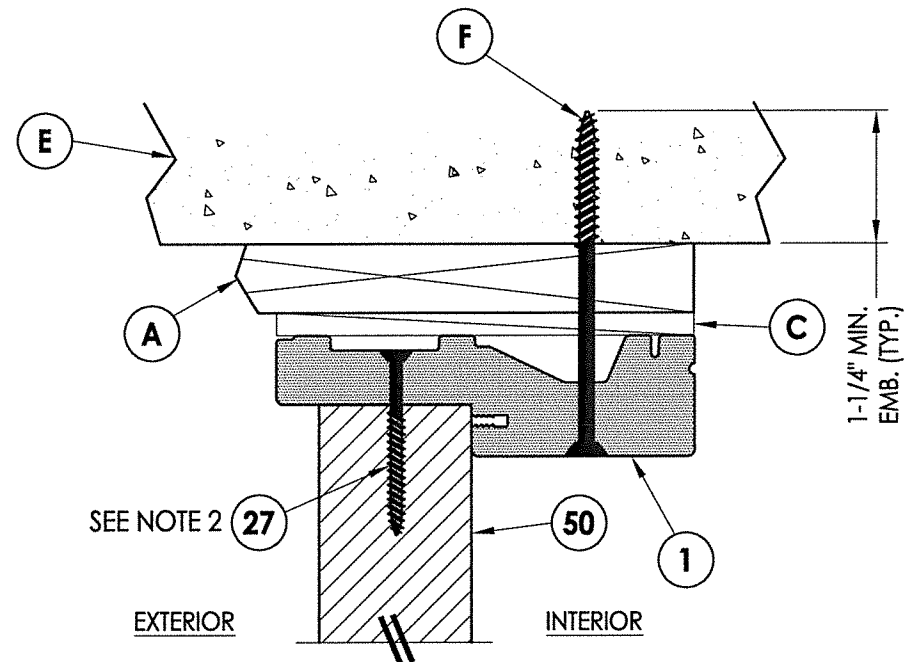

**5 VERTICAL CROSS SECTION**  
7 Shown w/ 1X sub-buck

**Notes:**

1. Sidelite assembly screws located 6" from each end and 4 more screws equally spaced between (6 screws total per side jamb).
2. Sidelite assembly screws located 10" from each end (2 screws total along head & sill).

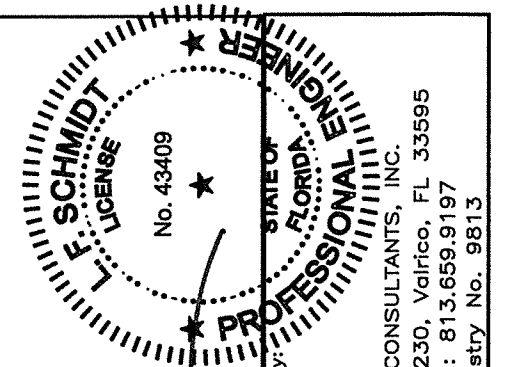

February 8, 2021

Documents Prepared By:  
Lyndon F. Schmidt  
P.E. No. 43409

**R.W. BUILDING CONSULTANTS, INC.**  
P.O. Box 230, Valrico, FL 33595  
Phone No.: 813.659.9197  
FBPE Registry No. 9813

PRODUCT: TRINITY FIBERGLASS PATIO DOOR "Impact"  
PART OR ASSEMBLY: HORIZONTAL & VERTICAL CROSS SECTIONS (1X BUCK)

NO.	DATE	BY	REVISIONS

DATE: 1/28/21  
SCALE: N.T.S.  
DWG. BY: RW  
CHK. BY: LFS  
DRAWING NO.: FL-37184.1  
SHEET 7 OF 12

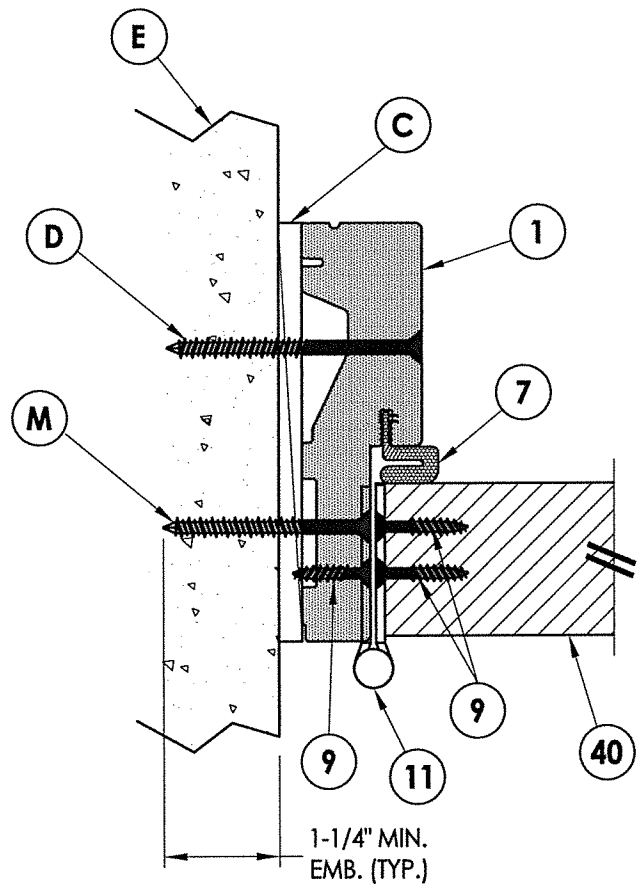

**1**  
**8** **HORIZONTAL CROSS SECTION**  
Shown Direct to Masonry

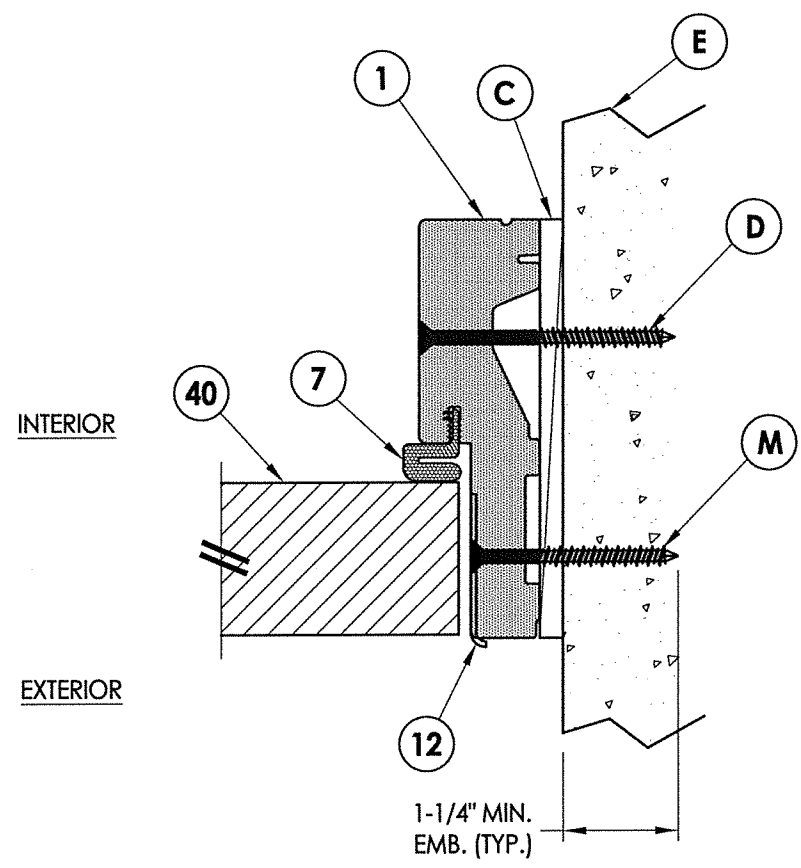

**2**  
**8** **HORIZONTAL CROSS SECTION**  
Shown Direct to Masonry

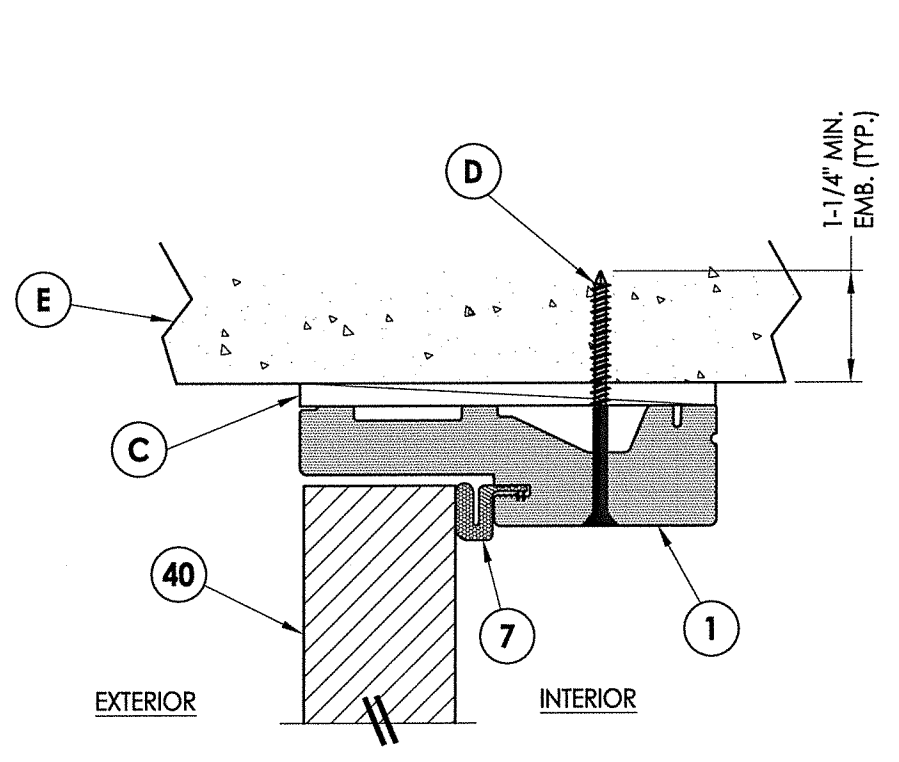

**4**  
**8** **VERTICAL CROSS SECTION**  
Shown Direct to Masonry

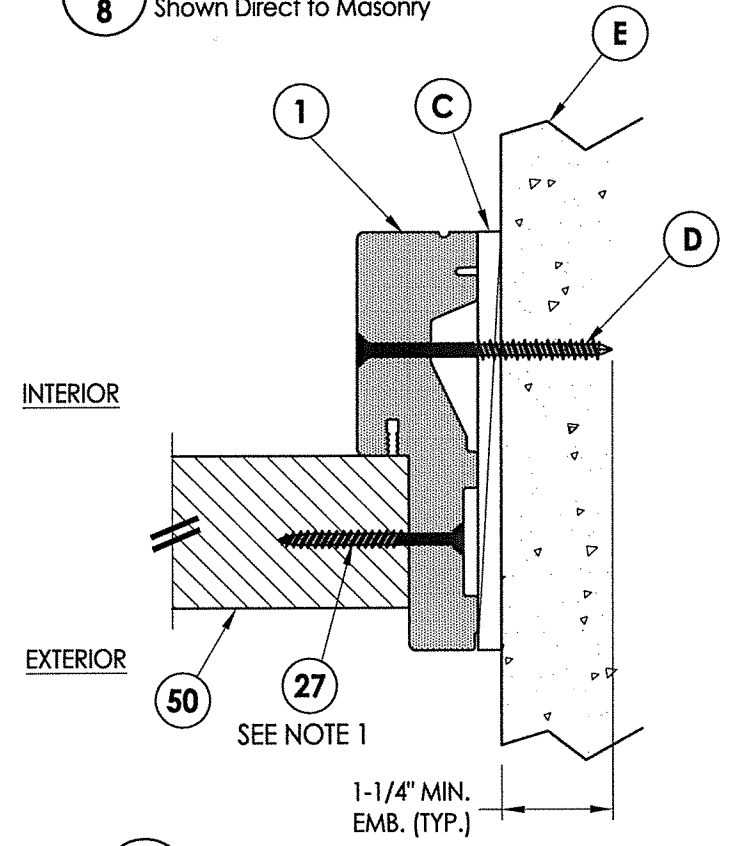

**3**  
**8** **HORIZONTAL CROSS SECTION**  
Shown Direct to Masonry

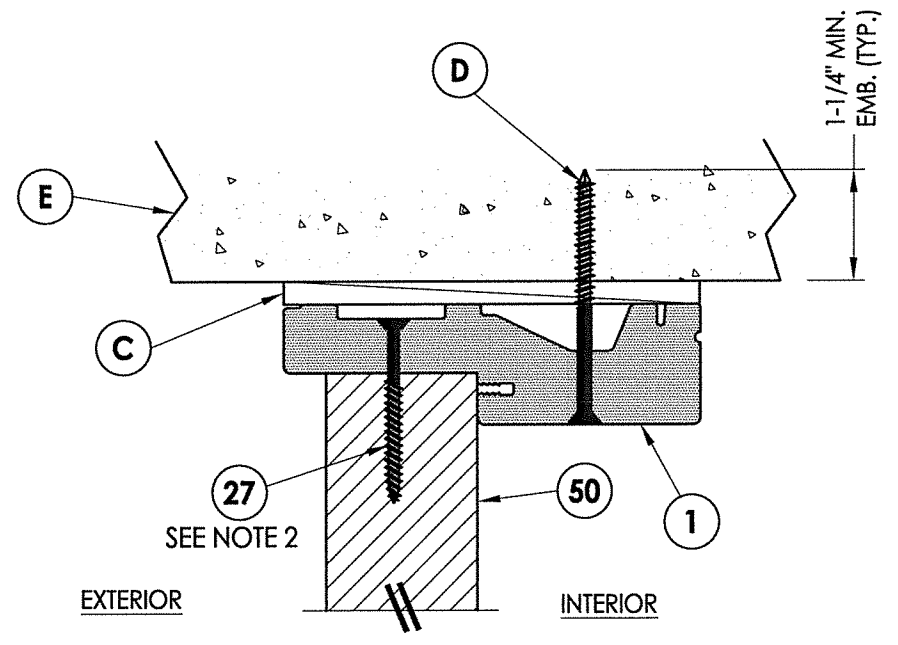

**5**  
**8** **VERTICAL CROSS SECTION**  
Shown Direct to Masonry

- Notes:
- Sidelite assembly screws located 6" from each end and 4 more screws equally spaced between (6 screws total per side jamb).
  - Sidelite assembly screws located 10" from each end (2 screws total along head & sill).

February 8, 2021  
 Documents Prepared By:  
 Lyndon F. Schmidt  
 P.E. No. 43409

R.W.  
 BUILDING CONSULTANTS, INC.  
 P.O. Box 230, Valrico, FL 33595  
 Phone No.: 813.659.9197  
 FBPE Registry No. 9813

PRODUCT:		TRINITY FIBERGLASS PATIO DOOR "Impact"	
PART OR ASSEMBLY:		HORIZONTAL & VERTICAL CROSS SECTIONS (DIRECT TO MASONRY)	
NO.	DATE	BY	REVISIONS
DATE: 1/28/21		SCALE: N.T.S.	
DWG. BY: RW		CHK. BY: LFS	
DRAWING NO.: FL-37184.1			
SHEET 8 OF 12			



Notes:

- 1. Sidelite assembly screws located 10" from each end (2 screws total along head & sill).

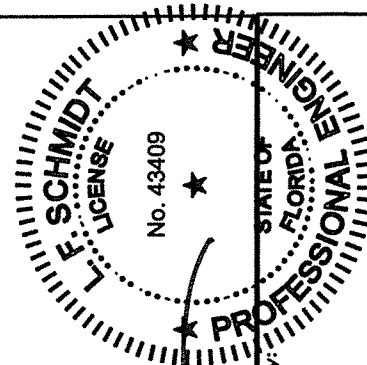
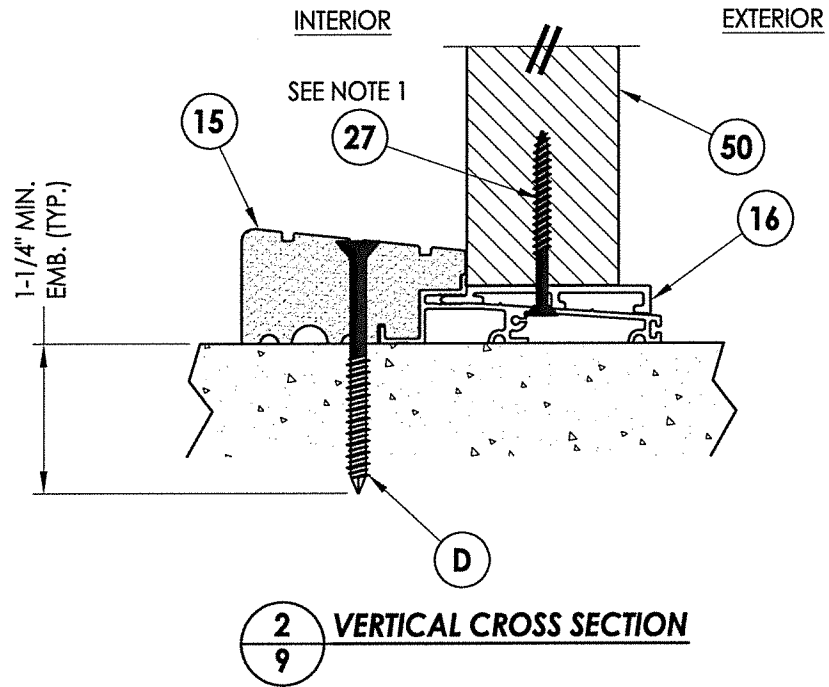
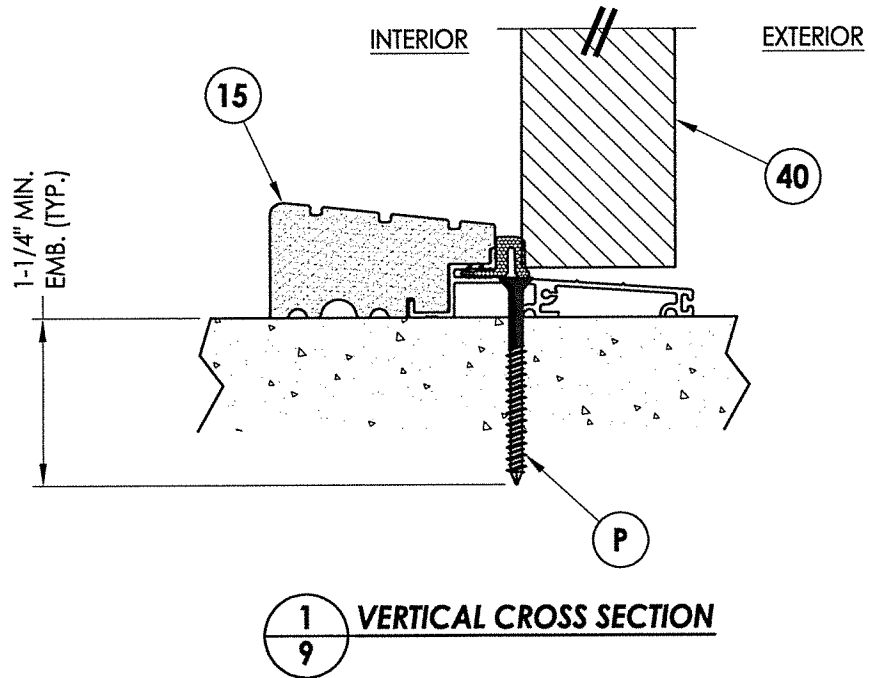

*LFS*

February 8, 2021

Documents Prepared By:  
Lyndon F. Schmidt  
P.E. No. 43409

*RW*  
BUILDING CONSULTANTS, INC.  
P.O. Box 230, Valrico, FL 33595  
Phone No.: 813.659.9197  
FBPE Registry No. 9813

PRODUCT:	TRINITY FIBERGLASS PATIO DOOR "Impact"	
PART OR ASSEMBLY:	VERTICAL CROSS SECTIONS (THRESHOLDS)	
NO.	DATE	BY
REVISIONS		
DATE:	1/28/21	
SCALE:	N.T.S.	
DWG. BY:	RW	
CHK. BY:	LFS	
DRAWING NO.:	FL-37184.1	
SHEET	9	OF 12

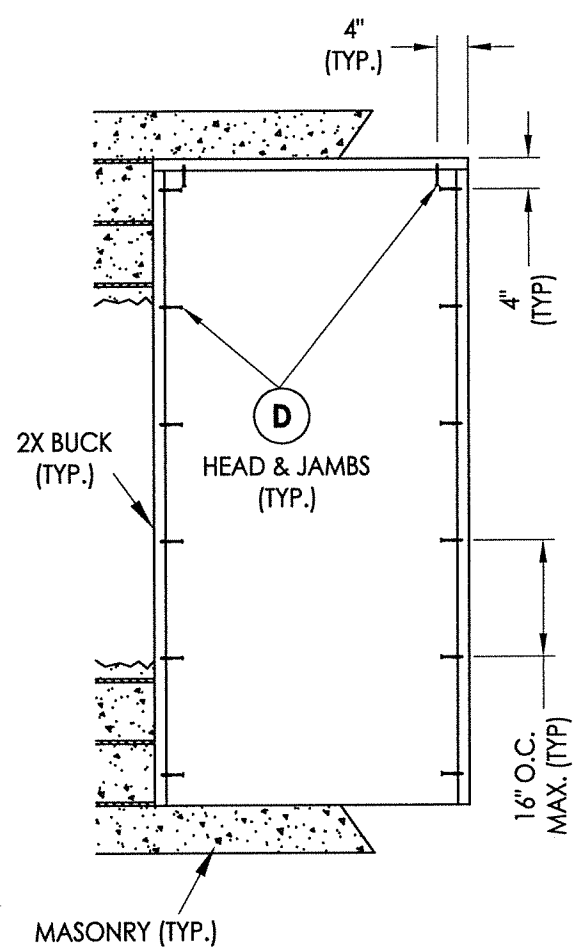

X

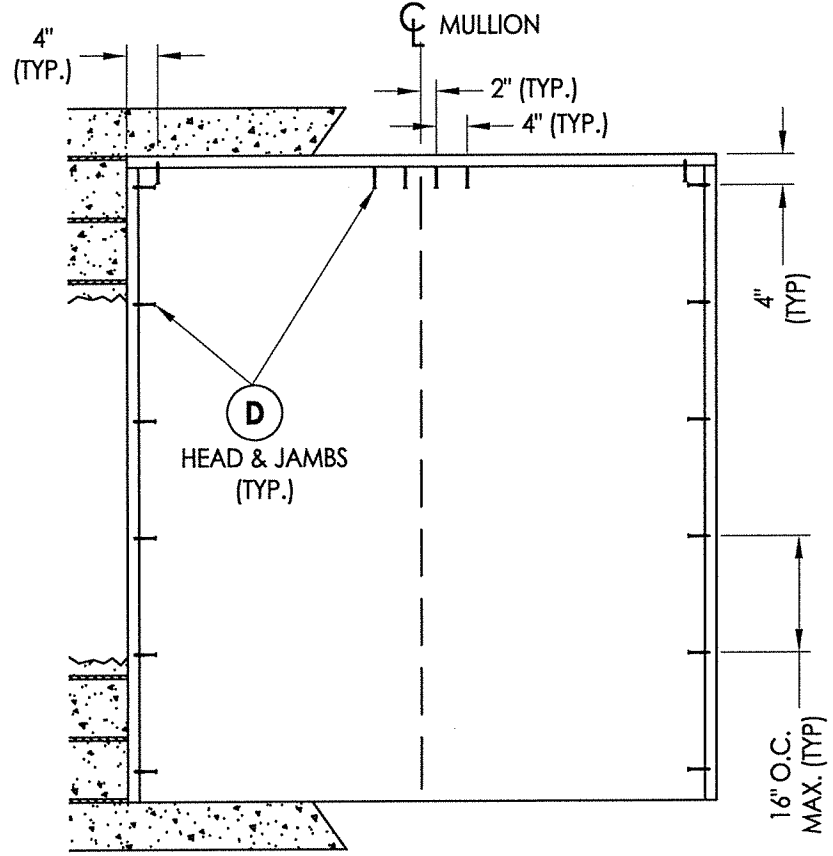

XO, OX

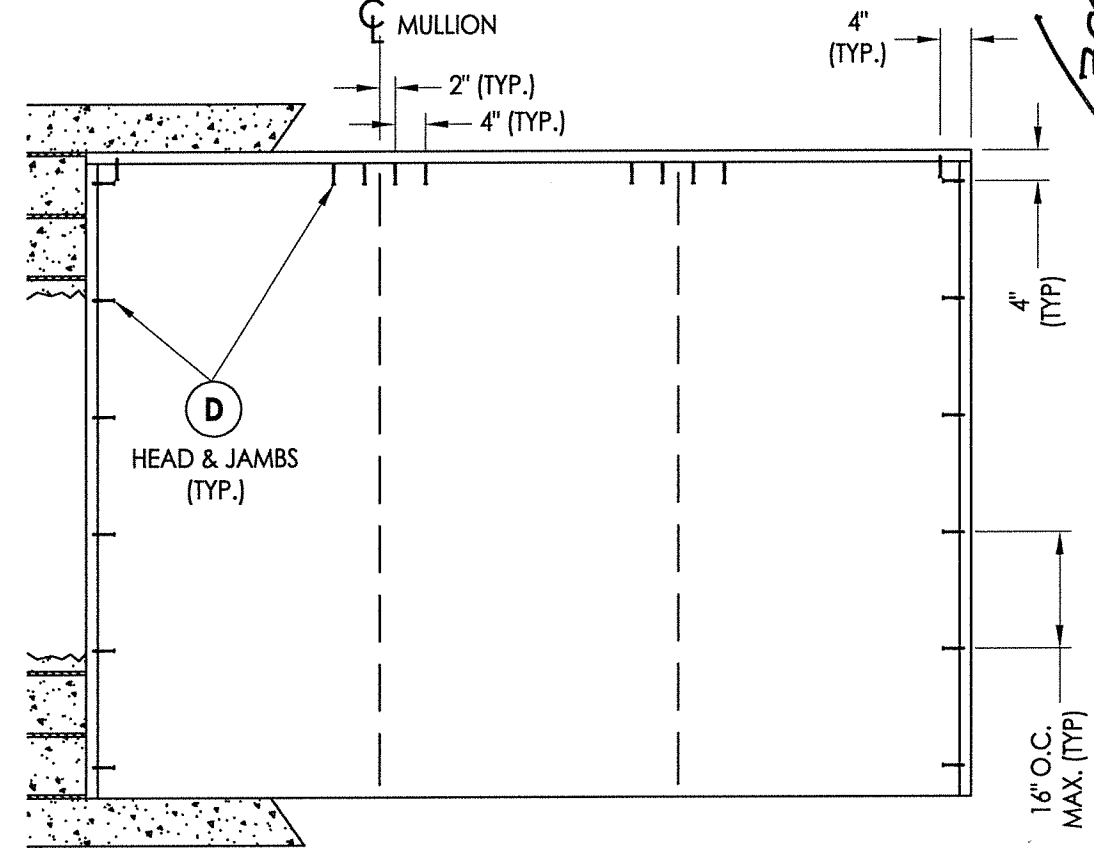

OXO, OOX, XO0

2X BUCK ANCHORING

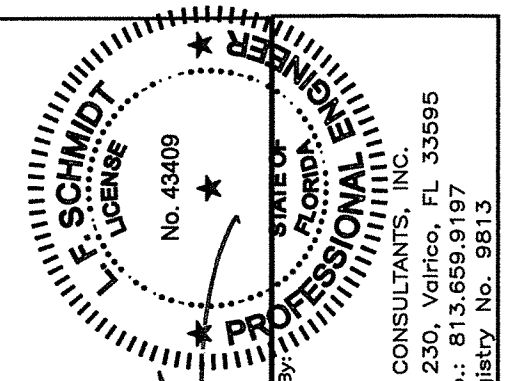

February 8, 2021  
 Documents Prepared By:  
 Lyndon F. Schmidt  
 P.E. No. 43409  
 R.W. BUILDING CONSULTANTS, INC.  
 P.O. Box 230, Valrico, FL 33595  
 Phone No.: 813.659.9197  
 FBPE Registry No. 9813

PRODUCT: TRINITY FIBERGLASS PATIO DOOR "Impact"	
PART OR ASSEMBLY: BUCK ANCHORING	
NO.	DATE
BY	REVISIONS
DATE: 1/28/21	
SCALE: N.T.S.	
DWG. BY: RW	
CHK. BY: LFS	
DRAWING NO.: FL-37184.1	
SHEET 10 OF 12	

Z:\Clients\Trinity Glass PERMANENT\TA - Florida Product Approvals\FL - 37184\C - Drawings\FL-37184-1.dwg

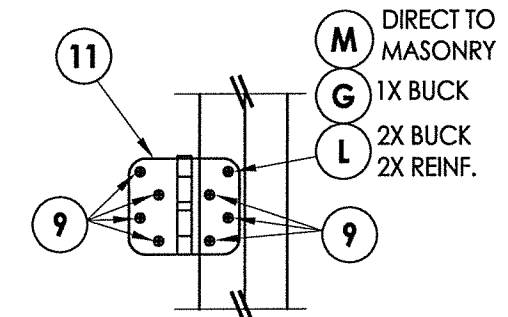
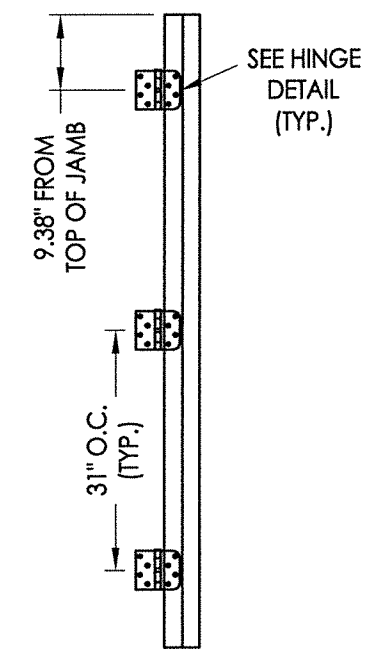
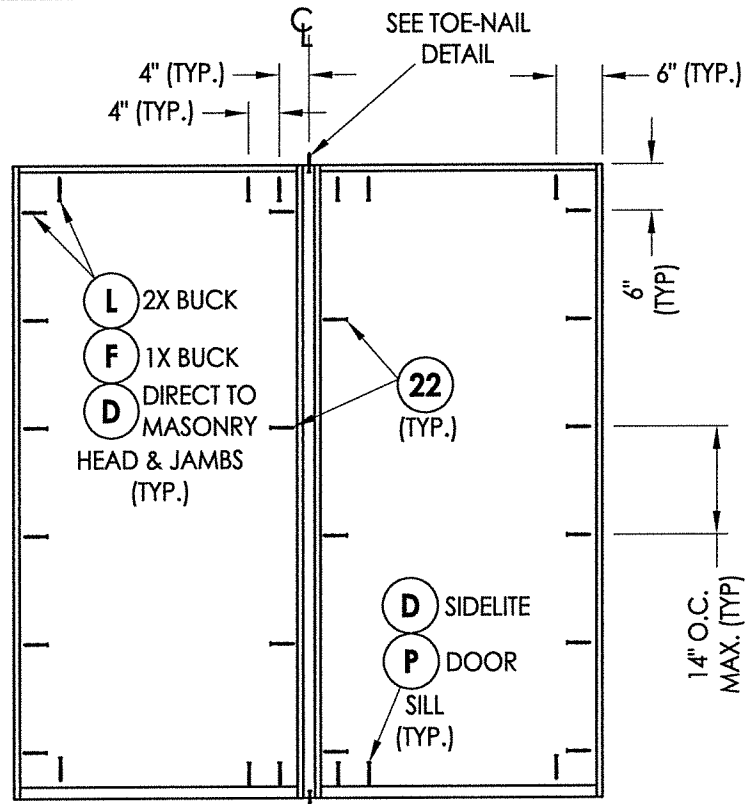
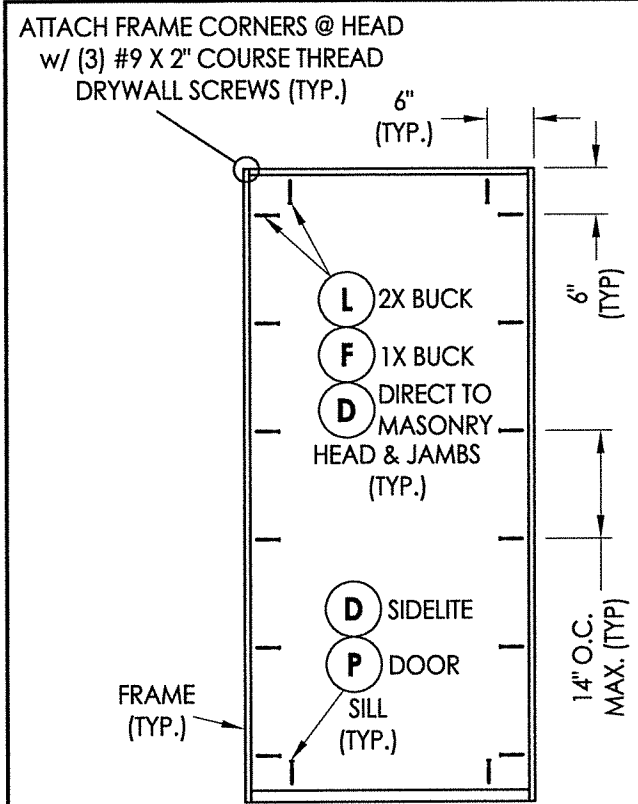

**HINGE DETAIL**

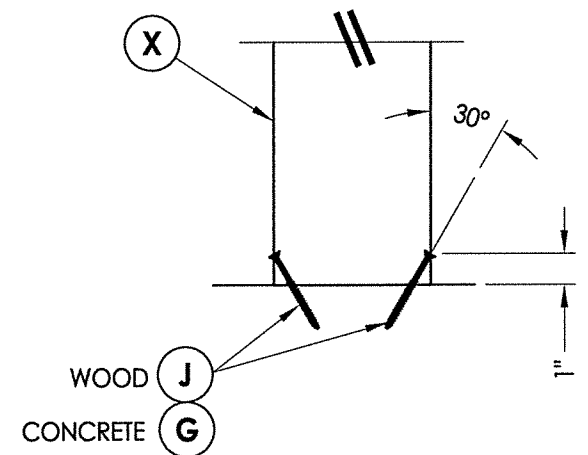
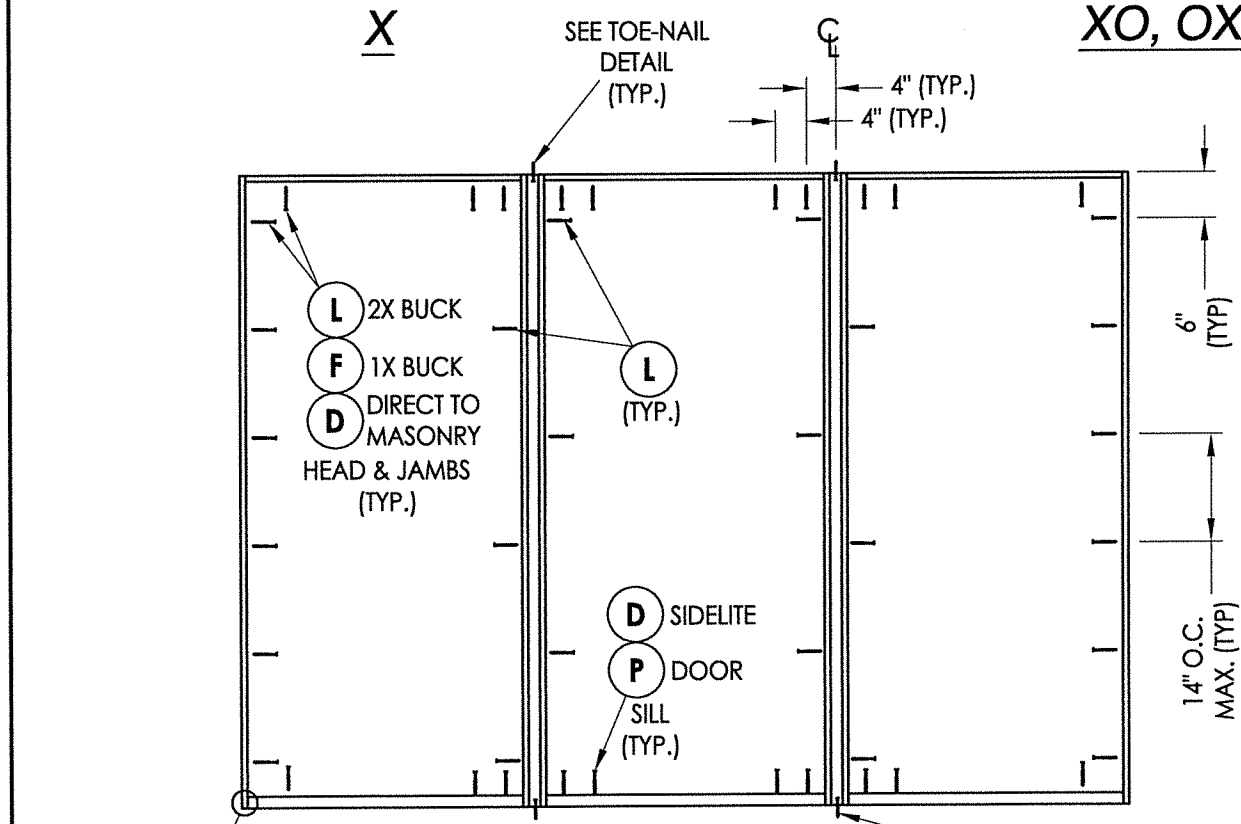

**TOE-NAIL DETAIL**

TYPICAL @ EACH 2X REINFORCEMENT (SHOWN @ SILL - HEAD SIMILAR)

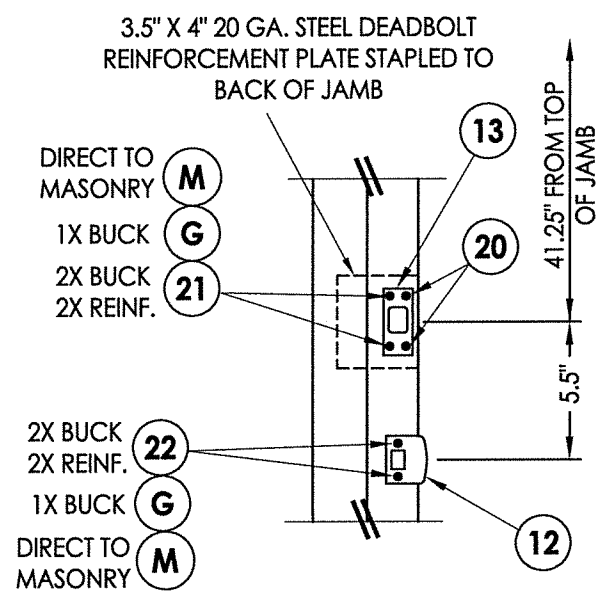

**LATCH & DEADBOLT DETAILS**

**HARDWARE DETAILS**

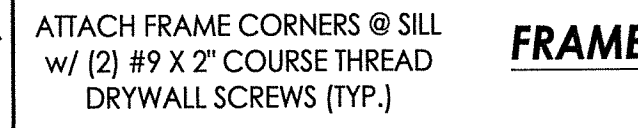

**FRAME ANCHORING**

February 8, 2021

Documents Prepared By: Lyndon F. Schmidt P.E. No. 43409

**R.W. BUILDING CONSULTANTS, INC.**  
 P.O. Box 230, Valrico, FL 33595  
 Phone No.: 813.659.9197  
 FBPE Registry No. 9813

PRODUCT:	TRINITY FIBERGLASS PATIO DOOR "Impact"	
PART OR ASSEMBLY:	FRAME ANCHORING & HARDWARE DETAILS	
NO.	DATE	BY
REVISIONS		
DATE: 1/28/21		
SCALE: N.T.S.		
DWG. BY: RW		
CHK. BY: LFS		
DRAWING NO.: FL-37184.1		
SHEET 11 OF 12		

BILL OF MATERIALS		
ITEM #	DESCRIPTION	MATERIAL
A	1X BUCK (G >= 0.42)	WOOD
B	2X BUCK (G >= 0.42)	WOOD
C	1/4" MAX. SHIM SPACE	-
D	1/4" X 2-3/4" PFH DeWALT OR ITW CONCRETE SCREW	STEEL
E	MASONRY - 3,000 PSI MIN. CONCRETE CONFORMING TO ACI 301 OR HOLLOW BLOCK CONFORMING TO ASTM C90	CONCRETE
F	1/4" X 3-3/4" PFH DeWALT OR ITW CONCRETE SCREW	STEEL
G	3/16" X 3-1/4" PFH ITW CONCRETE SCREW	STEEL
J	#10 X 3" PFH WOOD SCREW	STEEL
L	#10 X 2-1/2" PFH WOOD SCREW (1.15" MIN. EMB.)	STEEL
M	3/16" X 2-1/4" PFH ITW CONCRETE SCREW	STEEL
P	1/4" X 2-1/4" PFH DeWALT OR ITW CONCRETE SCREW	STEEL
X	2X REINFORCEMENT (SG = 0.55)	WOOD
1	PVC JAMB	COMP.
7	WEATHERSTRIP	FOAM
9	#9 X 3/4" PFH WOOD SCREW	STEEL
10	#9 X 1" PFH WOOD SCREW	STEEL
11	4" X 4" HINGE	STEEL
12	LATCH STRIKE PLATE	STEEL
13	DEADBOLT STRIKE PLATE	STEEL
15	OUTSWING THRESHOLD	ALUM/COMP
16	OUTSWING SIDELITE ADAPTER	PVC
20	#9 X 1/2" PFH WOOD SCREW	STEEL
21	#12 X 2-1/2" PFH WOOD SCREW	STEEL
22	#8 X 2-1/2" PFH WOOD SCREW	STEEL
27	#10 X 2" PFH SMS	STEEL
40	DOOR PANEL	-
50	SIDELITE PANEL	-

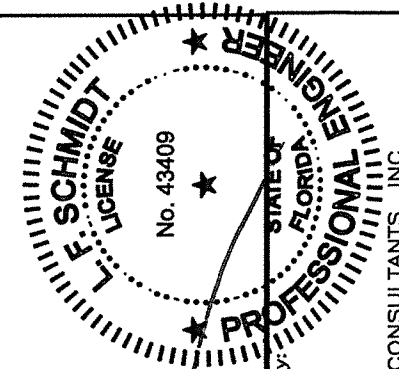
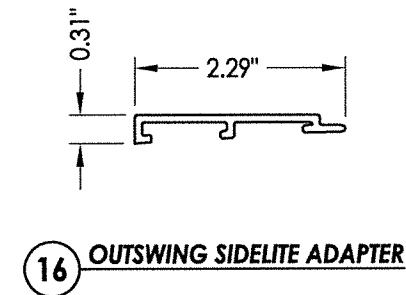
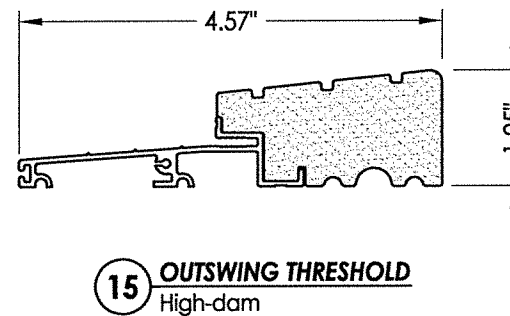
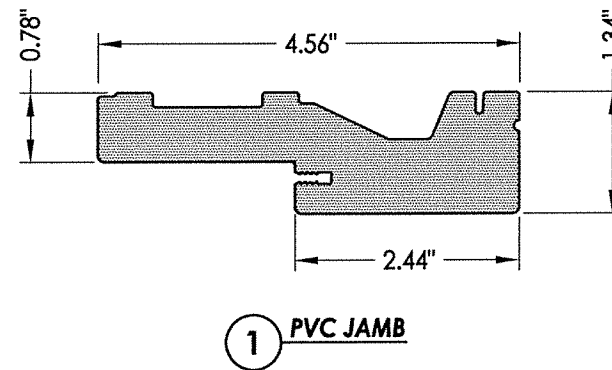

February 8, 2021  
 Documents Prepared By: Lyndon F. Schmidt  
 P.E. No. 43409  
 R.W. BUILDING CONSULTANTS, INC.  
 P.O. Box 230, Valrico, FL 33595  
 Phone No.: 813.659.9197  
 FBPE Registry No. 9813

PRODUCT: TRINITY FIBERGLASS PATIO DOOR "Impact"  
 PART OR ASSEMBLY: BILL OF MATERIALS & COMPONENTS

NO.	DATE	REVISIONS

**CONCRETE ANCHOR NOTES:**

- Concrete anchor locations at the corners may be adjusted to maintain the min. edge distance to mortar joints.
- Concrete anchor locations noted as "MAX. ON CENTER" must be adjusted to maintain the min. edge distance to mortar joints, additional concrete anchors may be required to ensure the "MAX. ON CENTER" dimension are not exceeded.
- Concrete anchor table:

ANCHOR TYPE	ANCHOR SIZE	MIN. EMBEDMENT	MIN. CLEARANCE TO MASONRY EDGE	MIN. CLEARANCE TO ADJACENT ANCHOR
ITW BUILDEX TAPCON®	3/16"	1-1/4"	3"	1-1/2"
DeWALT ULTRACON®	1/4"	1-1/4"	2"	4"
DeWALT ULTRACON®	1/4"	1-1/4"	1"	4"

**WOOD SCREW INSTALLATION NOTES:**

- Maintain a minimum 5/8" edge distance, 1" end distance, & 1" o.c. spacing of wood screws to prevent the splitting of wood.

DATE: 1/28/21  
 SCALE: N.T.S.  
 DWG. BY: RW  
 CHK. BY: LFS  
 DRAWING NO.: FL-37184.1  
 SHEET 12 OF 12